

GENERAL ABBREVIATIONS

AFF	= ABOVE FINISH FLOOR	H	= HEIGHT
ARCH.	= ARCHITECT	ITI	= INSIDE TO INSIDE
B.D.	= BY OTHERS	(OPENING)	= (OPENING)
B.S.	= BOTH SIDE	L	= LENGTH
B.P.	= BASE PLATE	L1	= OPENING
		L2	= PANEL WIDTH
		NS	= NEAR SIDE
CL	= CENTER LINE	OC	= ON CENTER
CLR	= CLEARANCE	O.H.	= OPPOSITE HAND
CMU	= CONCRETE MASONRY UNIT	O/D	= OWNER/OPERATOR
DIM	= DIMENSIONS	OTO	= OUTSIDE TO OUTSIDE
Ø	= DIAMETER	(OPENING)	= (OPENING)
(E)	= EXISTING	P	= PANEL
FCTF	= FIELD CUT TO FIT	PL	= PLATE
FH	= FRAME HEIGHT	R.D.	= ROUGH OPENING
FL	= FLOOR	TYP.	= TYPICAL
FS	= FAR SIDE	VIF	= VERIFY IN FIELD
FW	= FRAME WIDTH	WIF	= WELD IN FIELD
GC	= GENERAL CONTRACTOR		
GL	= GROUND LEVEL		

GENERAL NOTES:

- 1) GENERAL CONTRACTOR WILL SPECIFY, APPROVE, VERIFY IN FIELD, AND GUARANTEE ALL DIMENSIONS SHOWN BEFORE FABRICATION. DIMENSIONS PROVIDED TO ATLANTIS PRODUCTS INC. FOR COMPONENTS INSTALLATION BY GC ARE GUARANTEED PLUMBED TRUE AND LEVELED.
- 2) REQUIRED ARCHITECTURAL DIMENSIONS OF FENCES, RAILINGS, AND SCREENS ARE PROVIDED BY THE GENERAL CONTRACTOR. THEY SHOULD MEET ALL THE THE APPLICABLE BUILDING CODES REQUIRED BY LOCAL, STATE, & OTHER REGULATORY AGENCIES.
- 3) UNLESS OTHERWISE INDICATED IN THE PLAN, ALL MECHANICAL FASTENERS ARE TO BE SUPPLIED BY AND RESPONSIBILITY OF THE INSTALLER.
- 4) ATLANTIS PRODUCTS INC. ASSUMES NO RESPONSIBILITY FOR THE DESIGN, CONSTRUCTION, AND INSTALLATION OF ANY MATERIALS SUPPLIED BY OTHERS.
- 5) ANY ADDITIONAL STRUCTURAL MEMBERS SUCH AS, GUSSETS, BRACES, KICKERS, EMBEDS, AND STIFFENERS, THAT MAYBE REQUIRED ARE NOT THE RESPONSIBILITY OF ATLANTIS PRODUCTS INC..
- 6) ACCIDENTAL DAMAGES & DEFECTS RESULTING FROM IMPROPER INSTALLATION AND VANDALISM ARE NOT COVERED UNDER THE WARRANTY PROVIDED BY ATLANTIS PRODUCTS INC.
- 7) ANY CLOUDED AREA IN THE DRAWING MUST BE REVIEWED BY THE ARCHITECT AND/OR OWNER. ADVISE ATLANTIS PRODUCTS INC. IN WRITING BY FAXING THE SUGGESTIONS OR BY REDLINING AND SIGNING THE DRAWINGS WITH THE ALTERNATIVE SOLUTIONS OR OPTIONS REGARDING THE MATTER.
- 8) ALL THE SURROUNDING STEEL, CONCRETE, CMU, PRECAST STRUCTURES, SUPPORT, FRAMES, COLUMNS OR POSTS MUST BE DESIGNED TO WITHSTAND ALL RESULTANT FORCES TRANSMITTED BY THE PANEL SCREENS AND RAILINGS.
- 9) THE MESH DRAWN BY HATCHES ARE SHOWN FOR ILLUSTRATION INTENT ONLY. DO NOT SCALE NOR MEASURE THE MESHES. MESH SPACINGS ARE SPECIFIED ON THE ISOMETRIC (OR 2-D) PANEL DRAWING SHOWN ON THE UPPER RIGHT HAND SIDE OF THE SHEET. ALIGNMENT OF MESHES ON SLOPED AND STRAIGHT PANELS MAY VARY DUE TO FIELD CONDITIONS AND SOME FACTORS ENCOUNTED IN THE FIELD SUCH AS , BUT NOT LIMITED TO, CONSTRUCTION ERRORS, MISFITS, OR IRREGULARITIES.
- 10) ALL THE ELEVATIONS AND DETAILS DRAWN ILLUSTRATE WELDED ROD ON THE NEAR SIDE, EXCEPT WHEN NOTED OTHERWISE.
- 11) PANEL DIMENSION ALLOWANCE ON FABRICATION TOLERANCE IS +/- 1/4" [+/- 6mm] ON ALL DIMENSIONS.

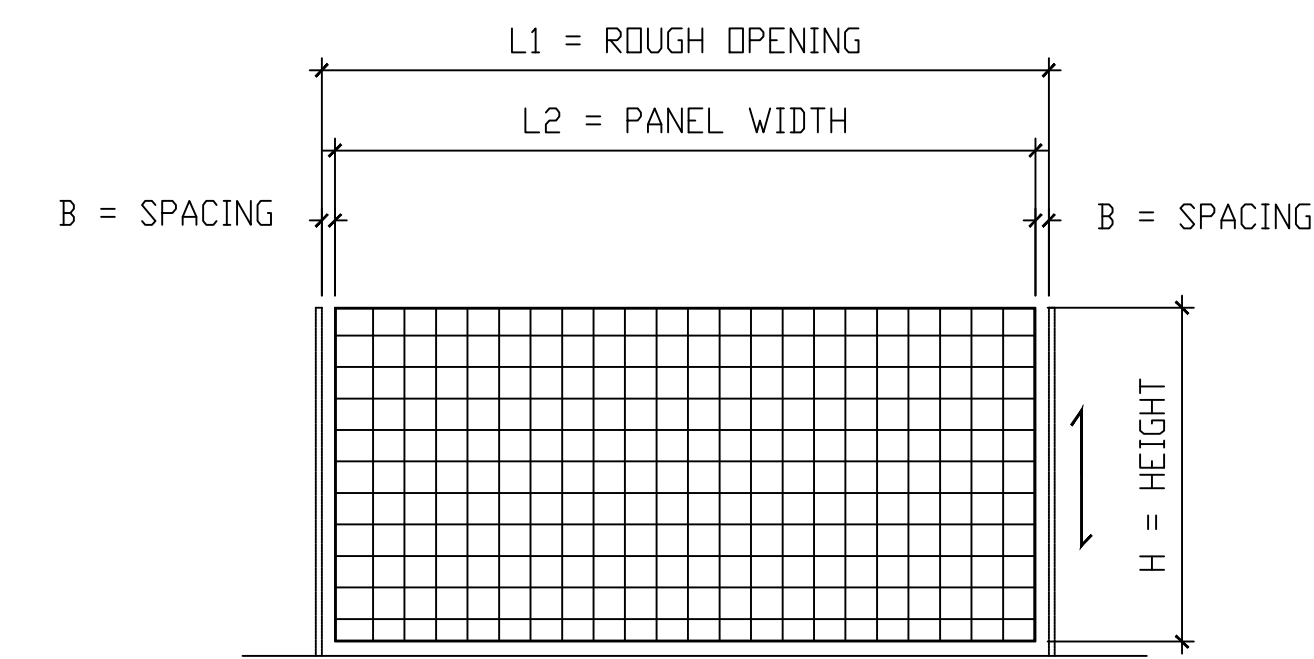

1
AI PANEL CHART LEGEND I
NOT TO SCALE

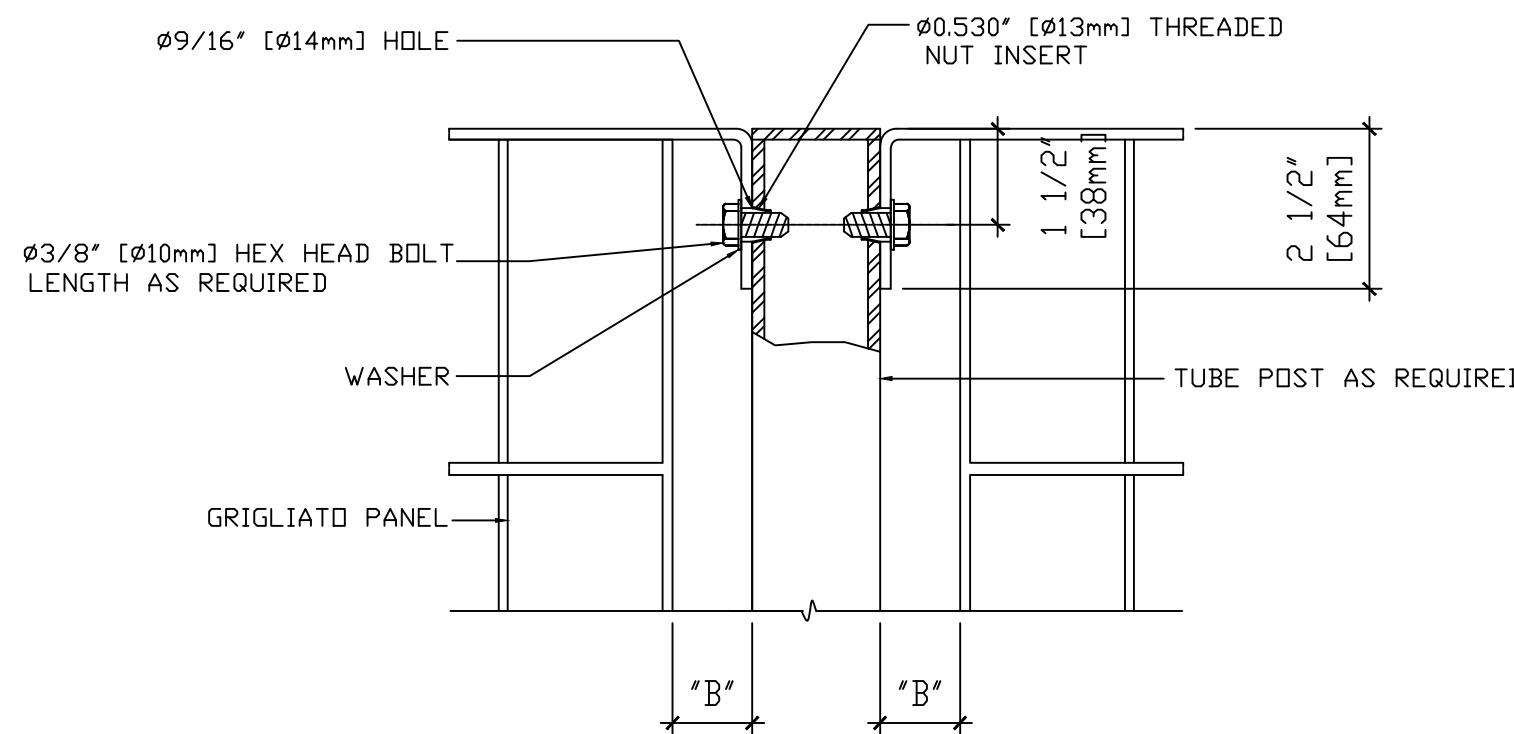

2
AI PANEL & POST ATTACHMENT DETAIL
NOT TO SCALE

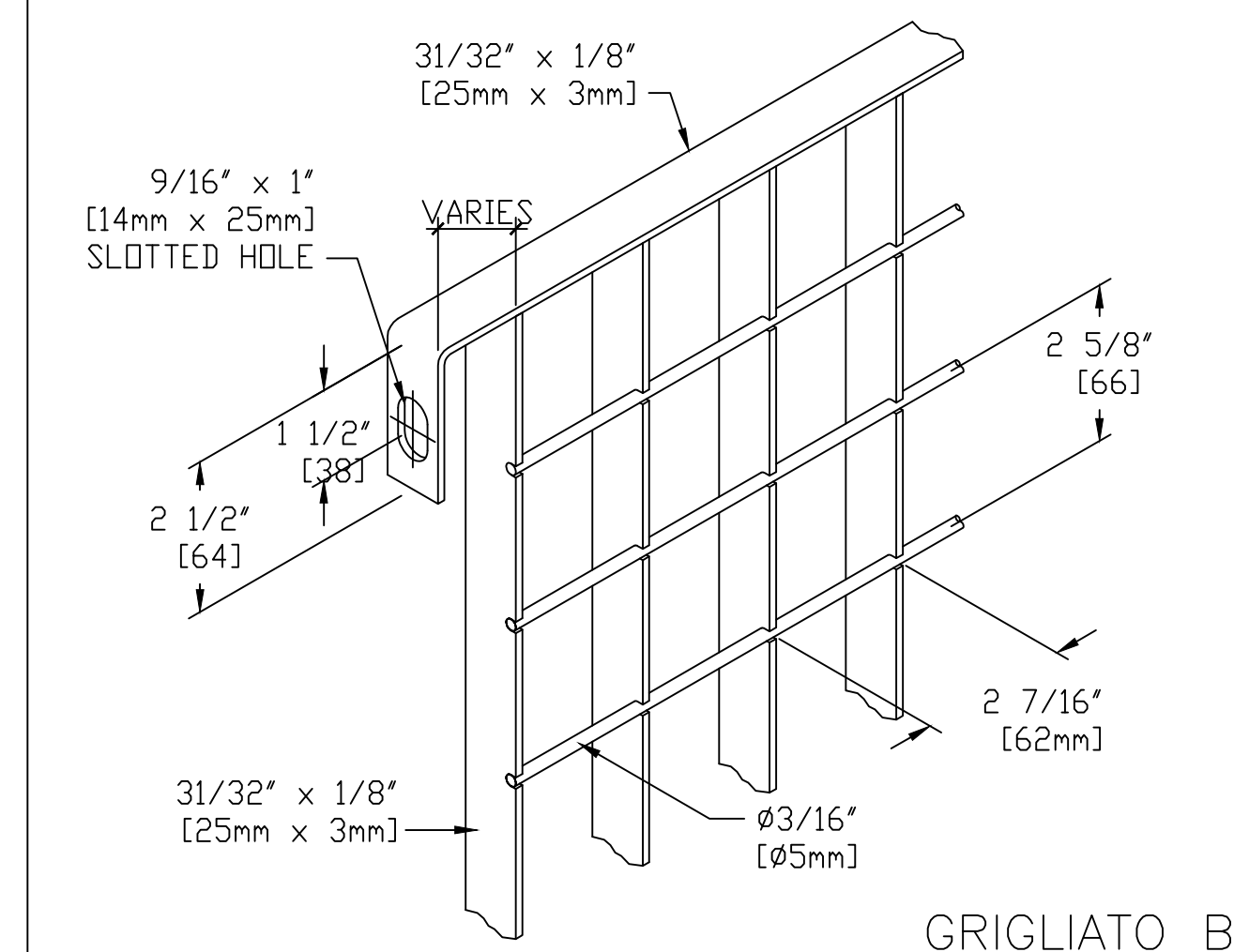
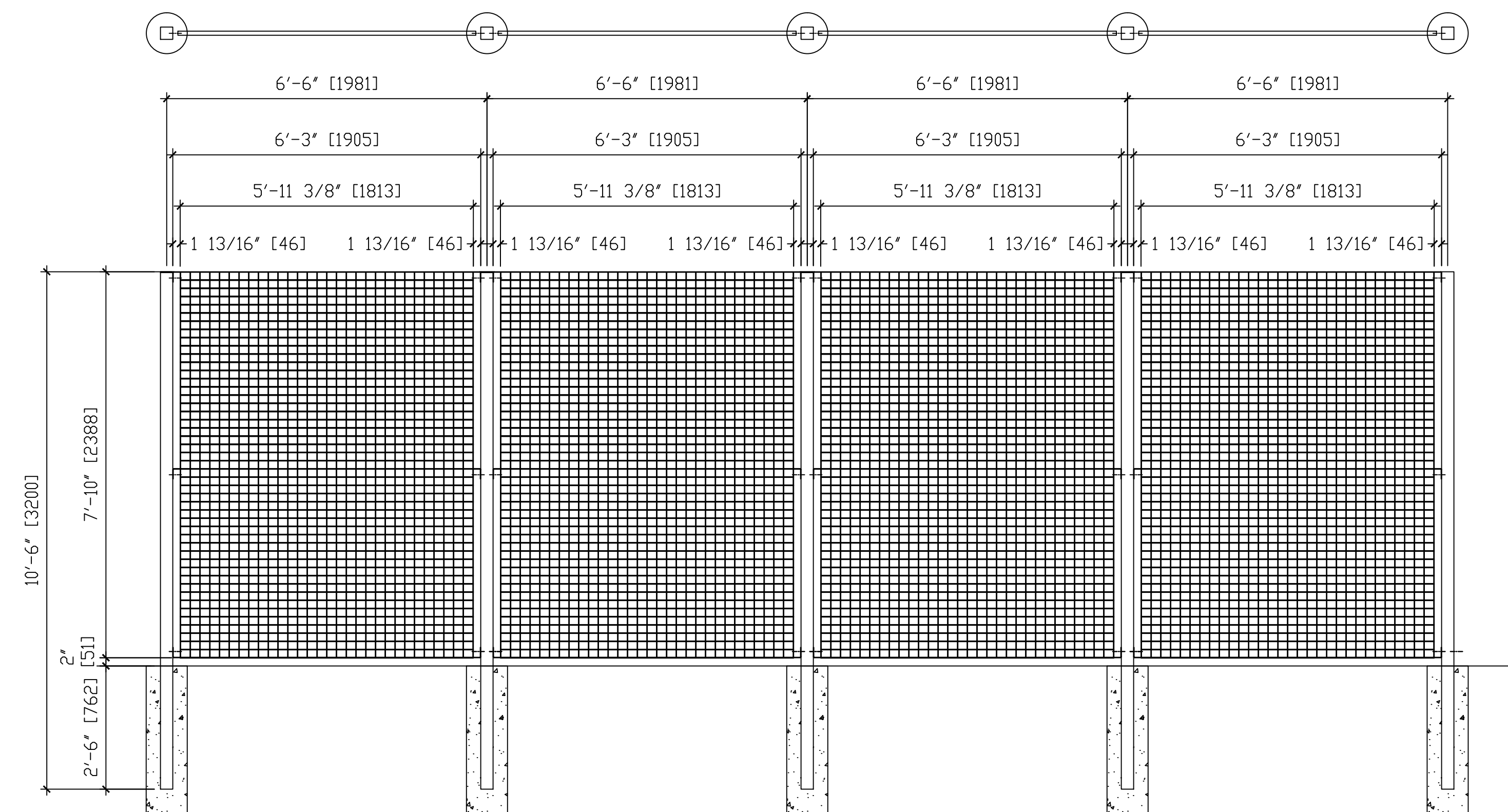

GRIGLIATO B

REV. DATE				
REV. BY				
REVISED ITEMS				
REV. NO.	Δ	Δ	Δ	Δ

CONTENTS:
MASTERSHEET, CHART,
DETAILS, NOTES

metalco
8185 SOUTH CASS AVENUE
DARIEN, IL 60561
TEL. (630) 971-9680 FAX. (630) 971-9860

DRAWING INDEX	
A1	MASTER SHEET, DETAILS & CHART
A2	FENCE LAYOUT AND ELEVATIONS
FINISH: GALVANIZED & POWDER COATED	
COLOR: PLEASE SELECT	
CUSTOMER SIGNATURE AND APPROVAL	
INFORMATION PROVIDED ON THIS DRAWING DOCUMENTS ARE VITAL TO THE CUSTOMER AND ATLANTIS PRODUCTS INC.. THE PRODUCTION OF THE COMPONENTS ARE DEPENDENT UPON THE ACCURACY OF INFORMATION PROVIDED TO ATLANTIS PRODUCTS INC. BY THE CUSTOMER. PLEASE REVIEW THE MEASUREMENTS IN THE DRAWINGS CAREFULLY, VERIFY THEM IN THE FIELD, DISCUSS AND CHECK THEM WITH YOUR DESIGNER AND CONTRACTOR. INDICATE NECESSARY CHANGES IN REDMARKS. UPON SIGNING THIS BOX, IT WILL SUPERSEDE ALL SIGNED AND AFFIXED STAMPED USED BY THE CUSTOMER FOR THEIR OWN PURPOSES AND OFFICE PROCEDURES. CHANGES AFTER THE FINAL APPROVAL MAY INCUR ADDITIONAL COSTS AND DELAYS IN PRODUCTION. FAILURE OF CUSTOMER TO COMPLY WITH THIS REQUEST RELIEVES METALCO OF ANY RESPONSIBILITY RESULTING FROM ANY ERROR.	
DATE SENT _____	APPROVED BY _____ (SIGNATURE)
SUBMITTAL # _____	DATE SIGNED _____
PLEASE INITIAL AND DATE THE FOLLOWING PAGES ON THE BOTTOM RIGHT HAND CORNER FOR THE PURPOSE OF DRAWING VERIFICATION.	
SHEET NO.	AI
1	□ X

PROJECT: GRIGLIATO "B" FENCE SYSTEM
ADDRESS: _____
DRAWN BY: F. C.
CHECKED BY: _____
SCALE: N/A
DATE: 05.22.08
JOB NO. -
SHEET NO. AI