

2-2 Omega Cantilever Slide Gate

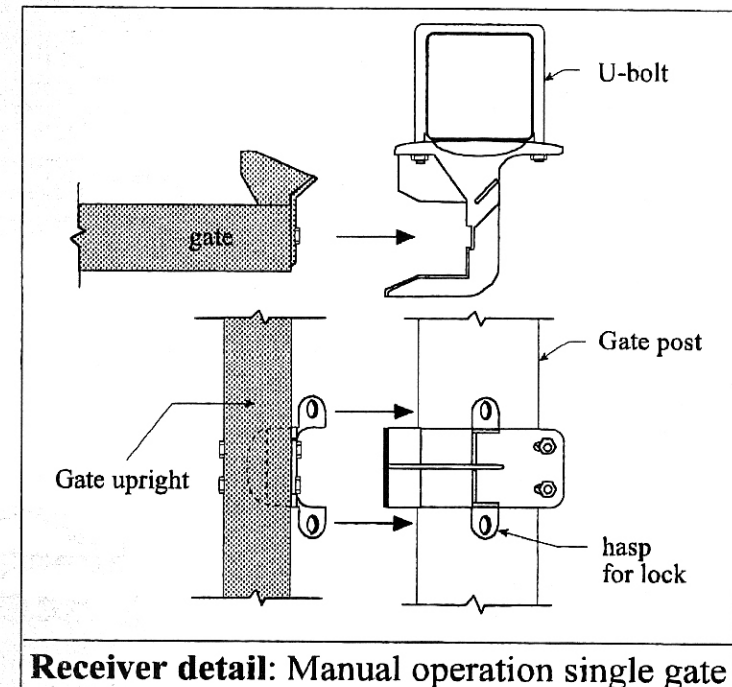
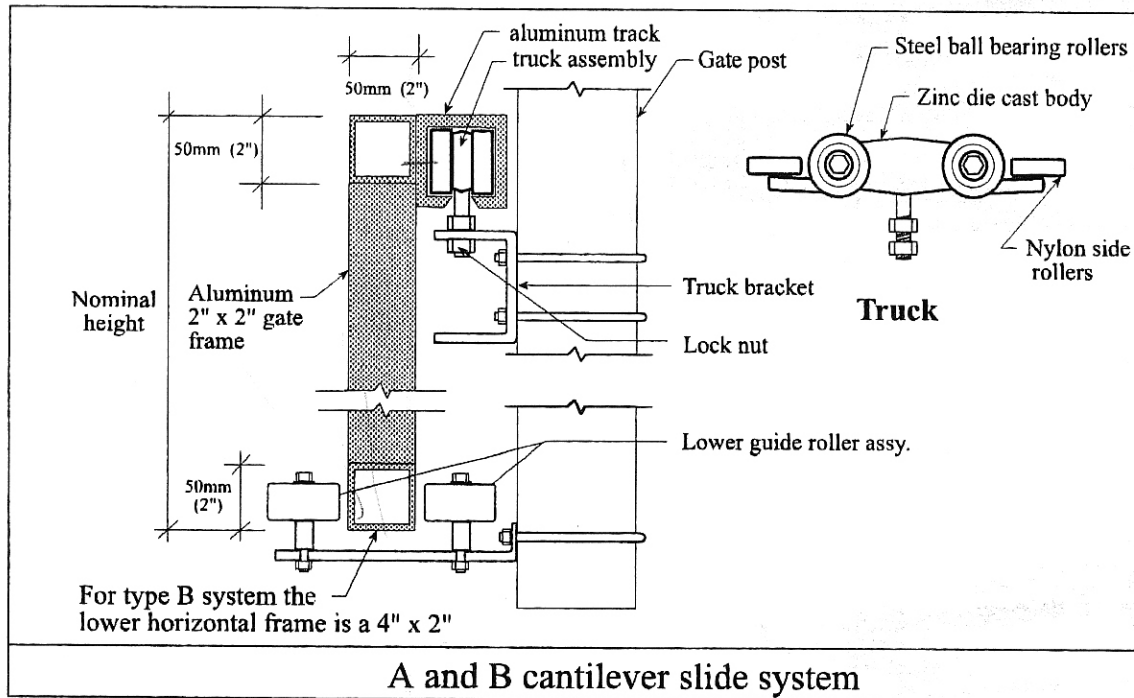

Model of Gate Design	Gate Leaf Size	Cantilever Support (Overhang)	Additional 2" Sq. Lateral Support	Bottom Rail	Truck Assemblies	Internal Uprights
A	6' (1830mm) to 10' (3040mm)	6' 6" (1980mm)	0		2	2" X 2"
	11' (3350mm) to 14' (4270mm)	7' 6" (2290mm)	0	2" X 2"	2	2" X 2"
	15' (4570mm) to 22' (6710mm)	10' 0" (3040mm)	0	2" X 2"	2	2" X 2"
B	23' (7010mm) to 30' (9010mm)	12' 0" (3660mm)	1	2" X 2"	2	2" X 2"
	31' (9450mm) to 35' (10670mm)	13' 6" (4120mm)	1	2" X 4"	4	2" X 2"
	36' (10970mm) to 40' (12190mm)	16' 0" (4880mm)	1	2" X 4"	4	2" X 2"

2" X 4"